



METAL DETECTOR

Ben Avellone
EEE3308 - EC1 Project

Overview

- Uses two (Colpitts) oscillators with the same resonant frequency
- When metal is placed near the detector coil, the resonant frequency for that oscillator changes
- Both oscillators output to a mixer which itself outputs the difference of the two signals
- Mixer output is fed through amplifiers and then to speaker for auditory feedback

Block Diagram

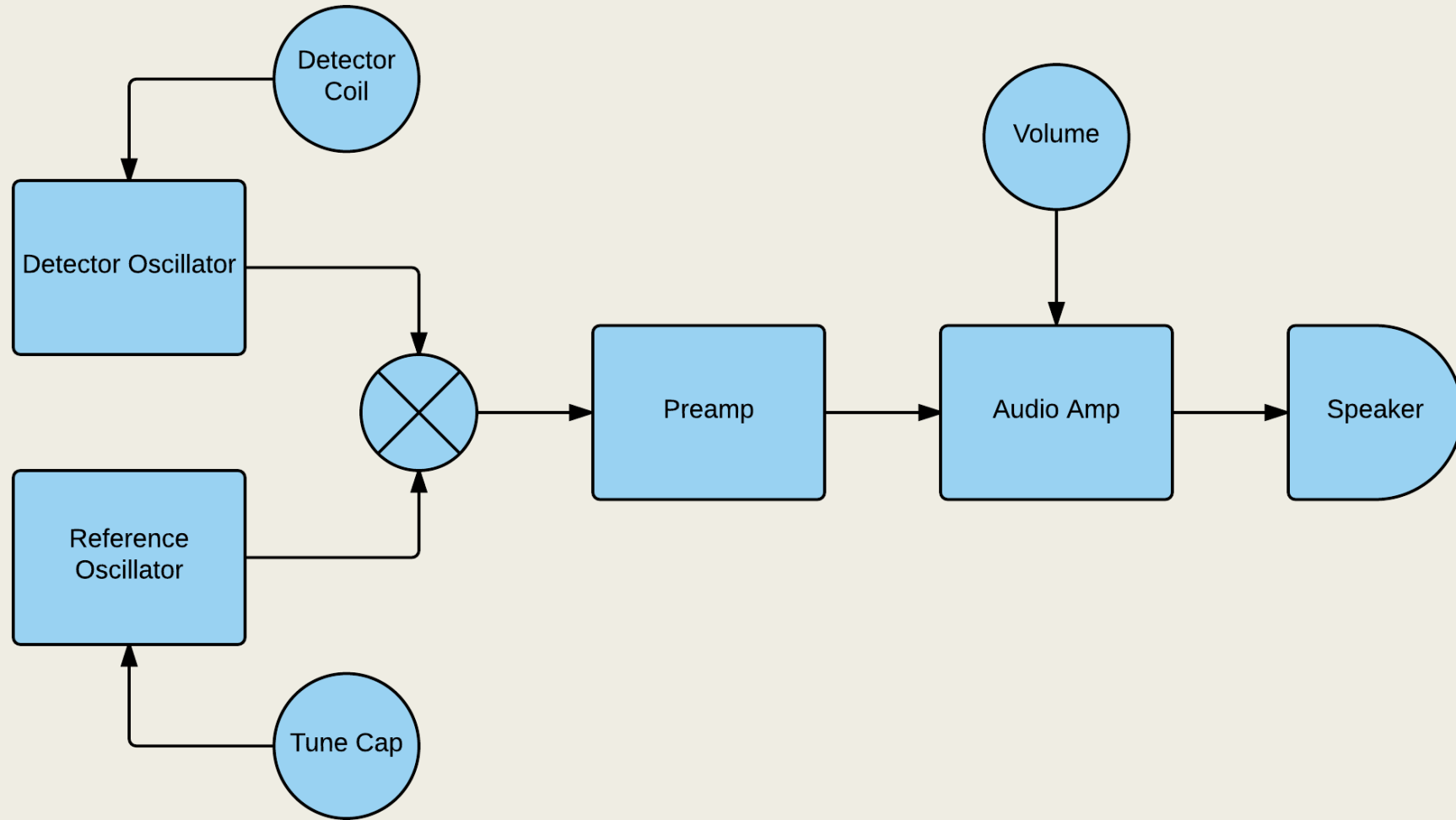

Circuit Design

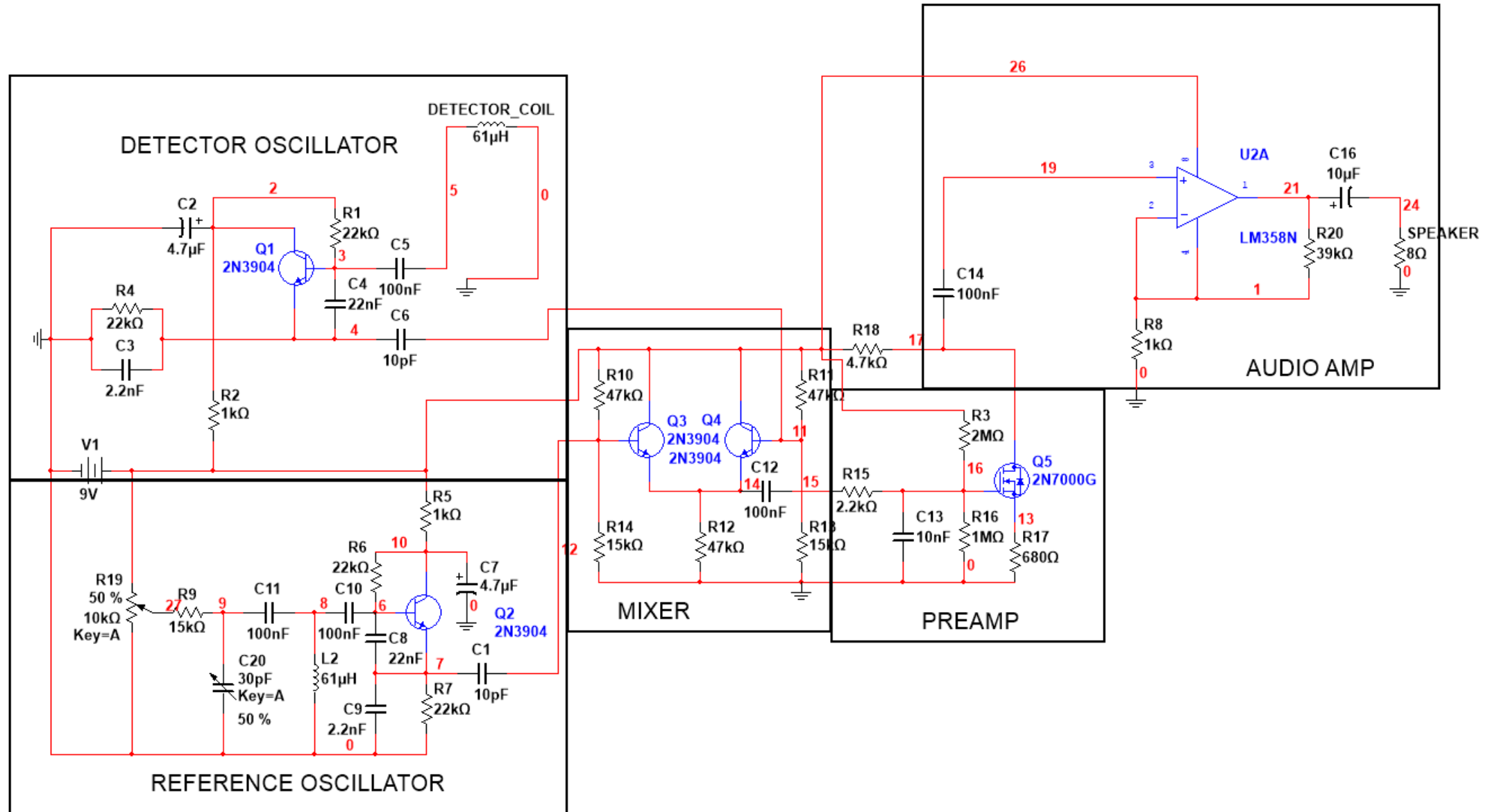

Detector Coil

- The search coil detects the presence of metal
 - *When metal is brought near the coil, the inductance changes*
 - *The inductance change causes the resonant frequency to change*
- Circuit outputs to a speaker for auditory feedback
 - *Frequency changes can be heard*
 - *Presence of metal causes auditory changes in output*

Testing Presence of Metal

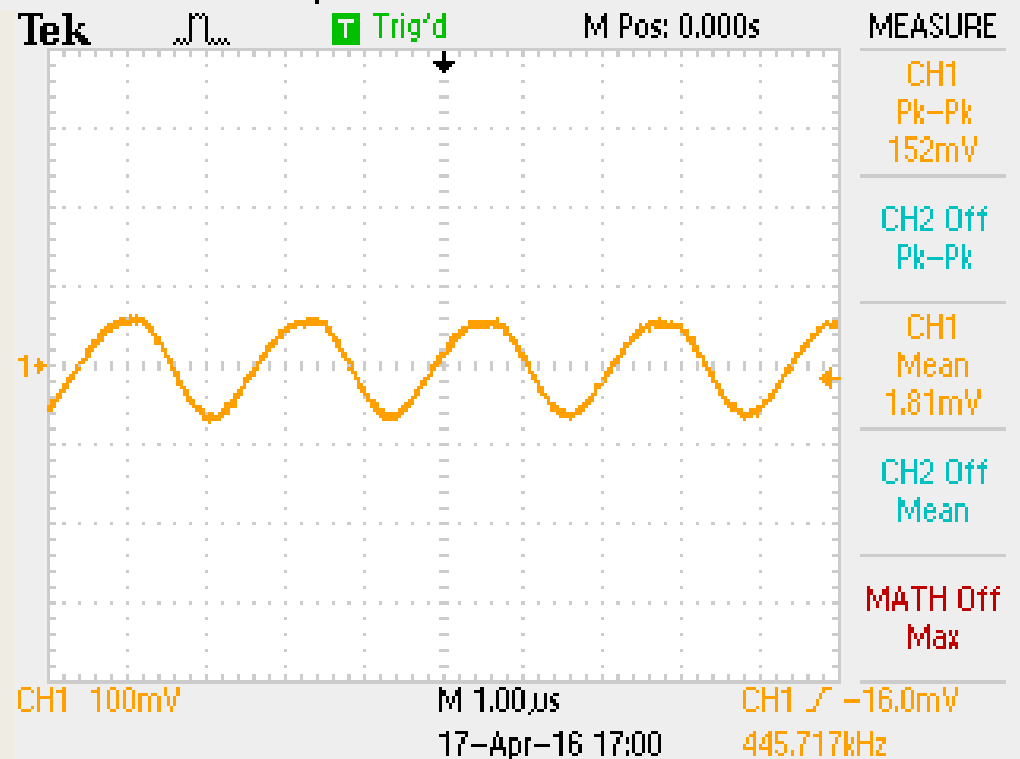
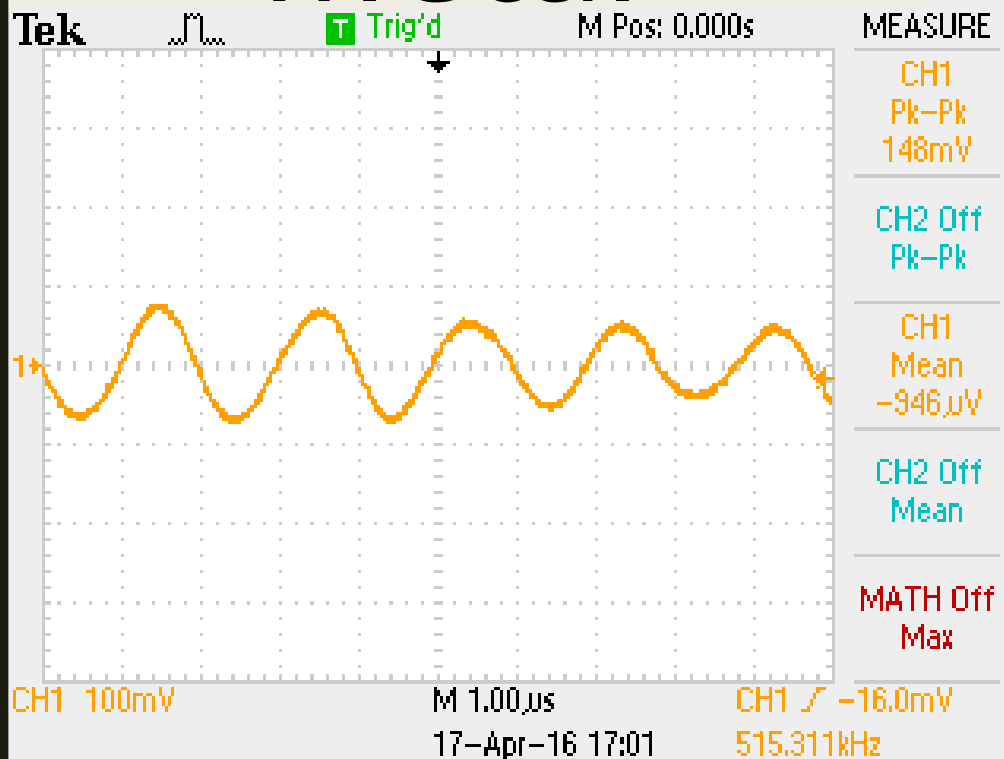
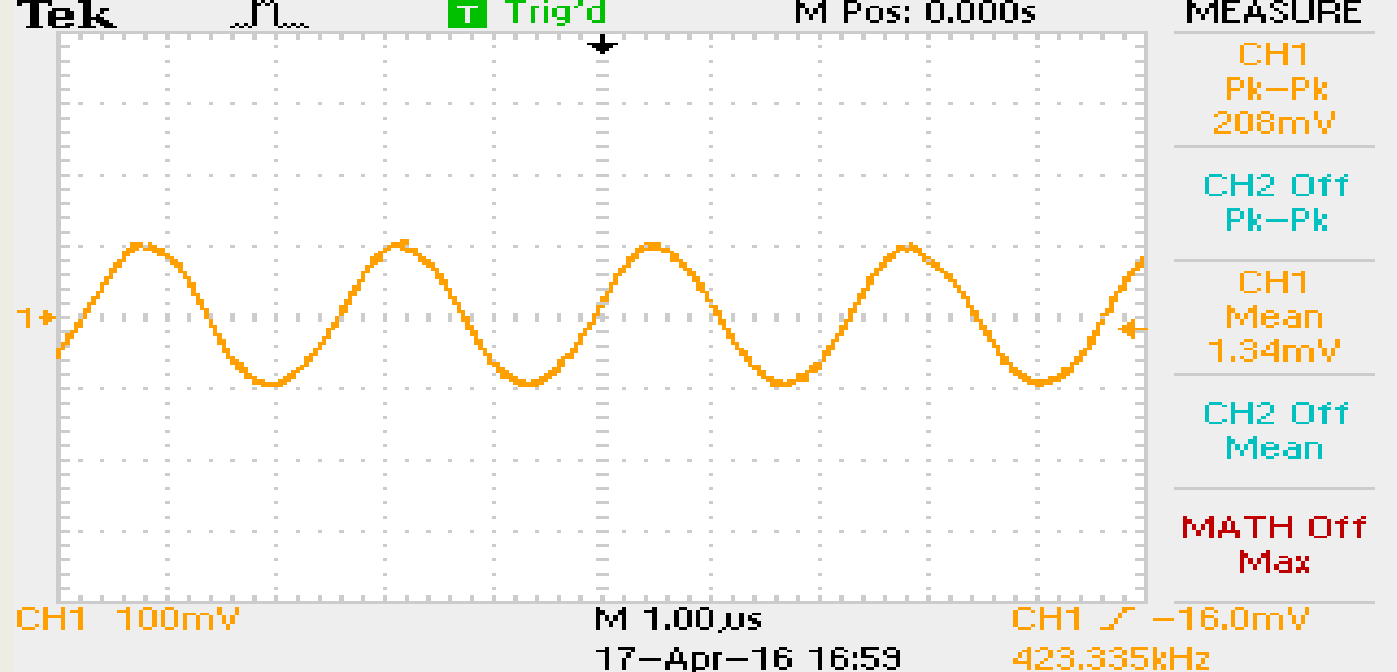

Testing Presence of Metal

With Bolt

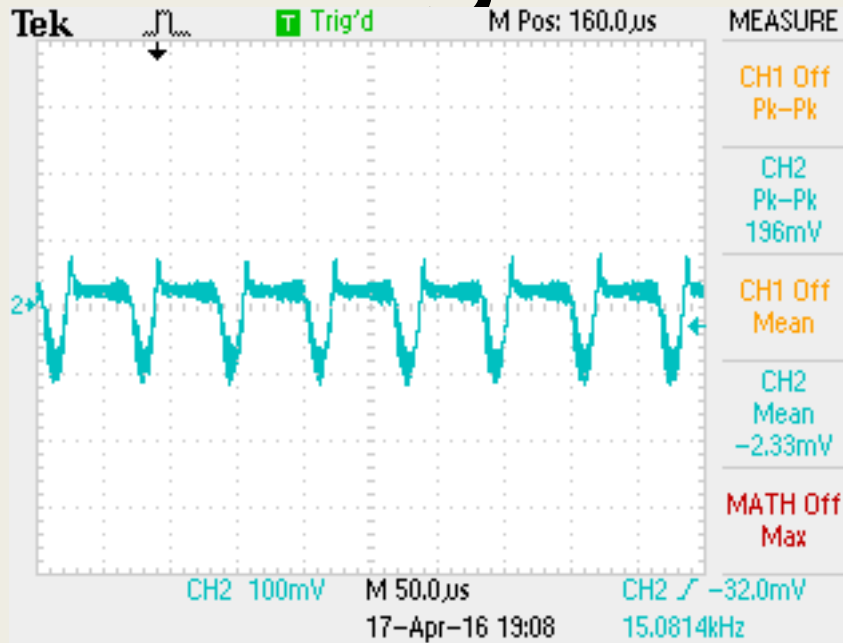

With Coil

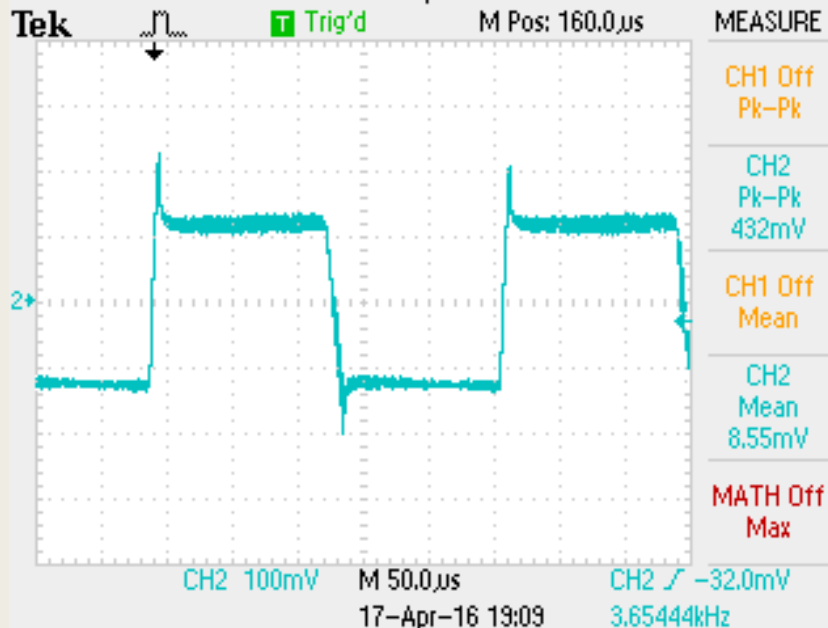

nyed)

Baselin

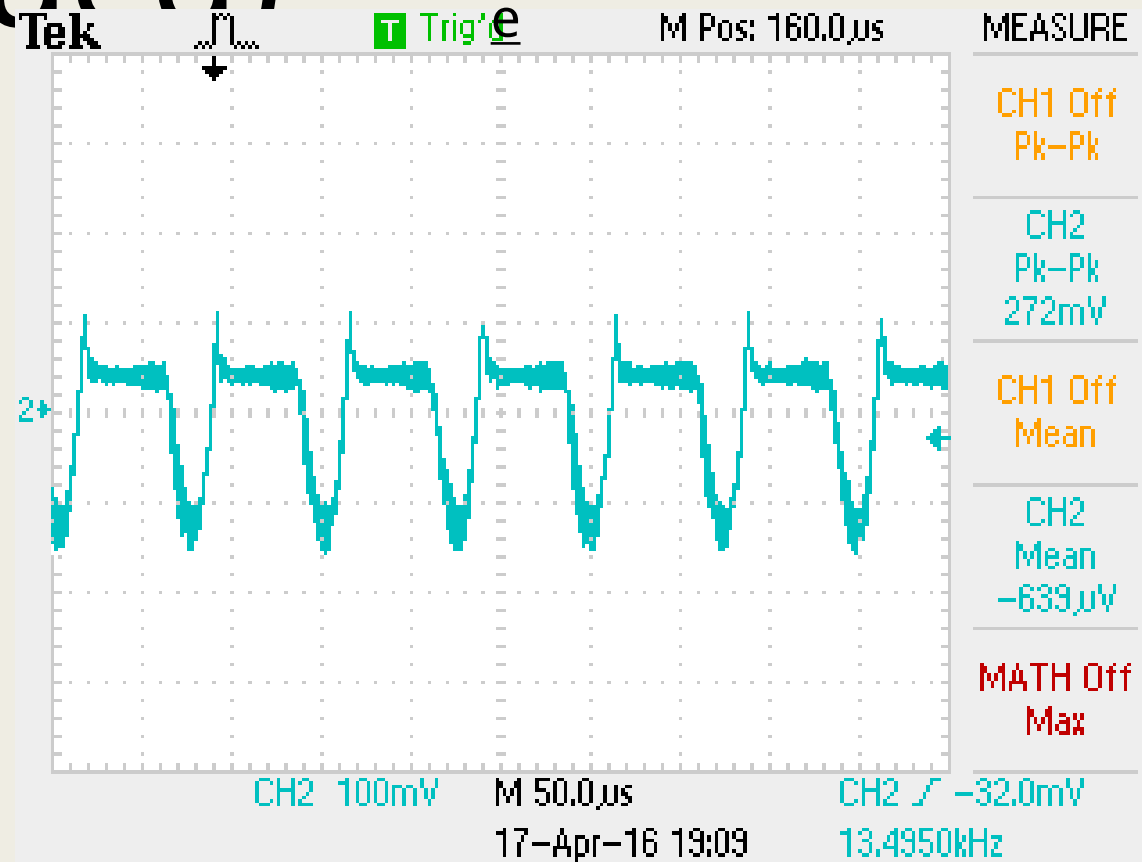

Speaker output

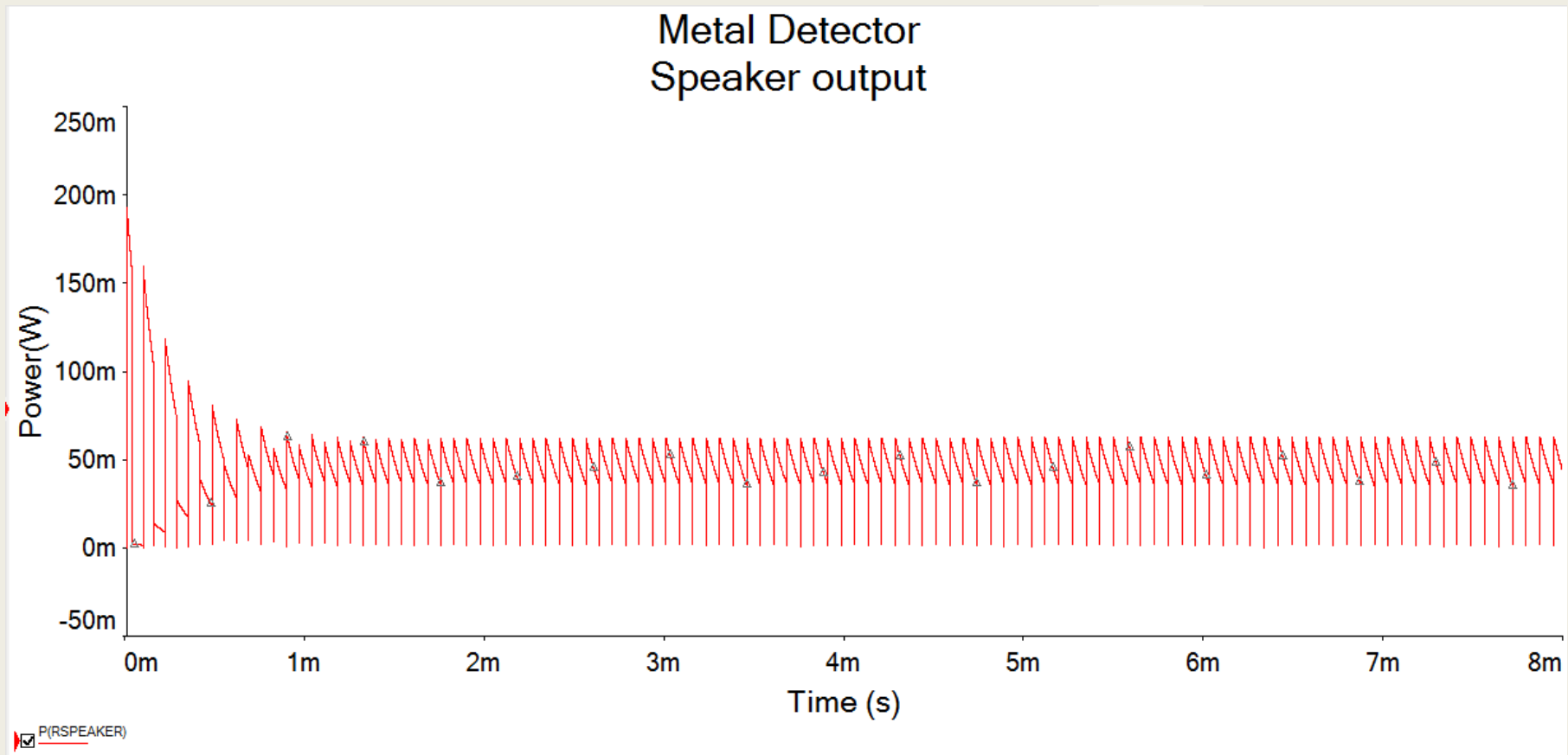

Demo

Questions?